

FPC-1736

17" Flexibility Multifunctional Touch Panel PC

17吋可扩充多功能多点触控平板计算器

Quick Reference Guide

快速使用指南

3rd Ed – 07 March 2023

Copyright Notice 版权声明

Copyright © 2023 Avalue Technology Inc., ALL RIGHTS RESERVED.

Part No. E2017F176A2R

FCC Statement (FCC RF 辐射暴露声明)



THIS DEVICE COMPLIES WITH PART 15 FCC RULES. OPERATION IS SUBJECT TO THE FOLLOWING TWO CONDITIONS:

(1) THIS DEVICE MAY NOT CAUSE HARMFUL INTERFERENCE.

(2) THIS DEVICE MUST ACCEPT ANY INTERFERENCE RECEIVED INCLUDING INTERFERENCE THAT MAY CAUSE UNDESIRE OPERATION.

THIS EQUIPMENT HAS BEEN TESTED AND FOUND TO COMPLY WITH THE LIMITS FOR A CLASS "A" DIGITAL DEVICE, PURSUANT TO PART 15 OF THE FCC RULES.

THESE LIMITS ARE DESIGNED TO PROVIDE REASONABLE PROTECTION AGAINST HARMFUL INTERFERENCE WHEN THE EQUIPMENT IS OPERATED IN A COMMERCIAL ENVIRONMENT. THIS EQUIPMENT GENERATES, USES, AND CAN RADIATE RADIO FREQUENCY ENERGY AND, IF NOT INSTALLED AND USED IN ACCORDANCE WITH THE INSTRUCTION MANUAL, MAY CAUSE HARMFUL INTERFERENCE TO RADIO COMMUNICATIONS.

OPERATION OF THIS EQUIPMENT IN A RESIDENTIAL AREA IS LIKELY TO CAUSE HARMFUL INTERFERENCE IN WHICH CASE THE USER WILL BE REQUIRED TO CORRECT THE INTERFERENCE AT HIS OWN EXPENSE.

本器材符合在不受控制环境下的FCC辐射暴露限制。最终用户必须跟从特定的操作指引以符合RF暴露的要求。传送器不能与任何天线或发射器共同放置。 联邦通讯委员会(FCC) 声明本器材符合FCC条例第15部份的要求。操作要视乎以下两个条件：(1) 本器材可能不会产生有害的干扰，以及(2) 本器材必须接受任何收到的干扰，包括可能引起操作上的干扰。任何未经负责遵守条例一方明示批准的修改或改装，将会取消用户操作本器材的权利。 15.21 我们在此对你作出警戒，任何未经遵守条例一方明示批准的修改或改装，将令用户失去操作本器材的权利。

Notice (注意)

This guide is designed for experienced users to setup the system within the shortest time. For detailed information, please always refer to the electronic user's manual.

此文件仅提供给拥有经验的使用者快速进行系统设定，若需要更详尽的资讯，请参考电子使用说明书

Copyright Notice (版权声明)

Copyright © 2023 Avalue Technology Inc., ALL RIGHTS RESERVED.

No part of this document may be reproduced, copied, translated, or transmitted in any form or by any means, electronic or mechanical, for any purpose, without the prior written permission of the original manufacturer.

未经原始制造商事先书面许可，不得出于任何目的以任何形式或任何方式（电子或机械）复制、复印、翻译或传播本文件的任何部分

Trademark Acknowledgement (商标声明)

Brand and product names are trademarks or registered trademarks of their respective owners.

品牌和产品名称是归属于所有者的商标或注册商标

Disclaimer (免责声明)

Avalue Technology Inc. reserves the right to make changes, without notice, to any product, including circuits and/or software described or contained in this manual in order to improve design and/or performance. Avalue Technology assumes no responsibility or liability for the use of the described product(s), conveys no license or title under any patent, copyright, or mask work rights to these products, and makes no representations or warranties that these products are free from patent, copyright, or mask work right infringement, unless otherwise specified. Applications that are described in this manual are for illustration purposes only. Avalue Technology Inc. makes no representation or warranty that such application will be suitable for the specified use without further testing or modification.

安勤科技保留更改任何产品的权利，恕不另行通知，包括本手册中描述或包含的电路和/或软件，以改进设计和/或性能。安勤科技对所描述产品的使用不承担任何责任或义务，不向这些产品转让任何专利、版权或屏蔽作品权下的许可或所有权，也不对这些产品不受专利保护

作出任何陈述或保证、版权或掩蔽作品权侵权，除非另有说明。本手册中描述的应用程序仅用于说明目的。安勤科技不声明或保证该应用程序在未经进一步测试或修改的情况下将适用于指定用途

Life Support Policy (生命支持政策)

Avalue Technology's PRODUCTS ARE NOT FOR USE AS CRITICAL COMPONENTS IN LIFE SUPPORT DEVICES OR SYSTEMS WITHOUT THE PRIOR WRITTEN APPROVAL OF Avalue Technology Inc.

As used herein:

1. Life support devices or systems are devices or systems which, (a) are intended for surgical implant into body, or (b) support or sustain life and whose failure to perform, when properly used in accordance with instructions for use provided in the labeling, can be reasonably expected to result in significant injury to the user.
2. A critical component is any component of a life support device or system whose failure to perform can be reasonably expected to cause the failure of the life support device or system, or to affect its safety or effectiveness.

未经安勤科技事先书面批准，安勤科技的产品不得用作生命支持设备或系统中的关键组件。

如本文所用：

1. 生命支持设备或系统是指以下设备或系统，(a) 用于手术植入体内，或 (b) 支持或维持生命，但如果按照本产品中提供的使用说明正确使用，则无法正常工作，可以合理预期会对用户造成重大伤害。
2. 关键组件是生命支持设备或系统的任何组件，其性能故障可合理预期会导致生命支持设备或系统发生故障，或影响其安全性或有效性

A Message to the Customer (给用户的讯息)

Avalue Customer Services(安勤客户服务)

Each and every Avalue's product is built to the most exacting specifications to ensure reliable performance in the harsh and demanding conditions typical of industrial environments. Whether your new Avalue device is destined for the laboratory or the factory floor, you can be assured that your product will provide the reliability and ease of operation for which the name Avalue has come to be known.

Your satisfaction is our primary concern. Here is a guide to Avalue's customer services. To ensure you get the full benefit of our services, please follow the instructions below carefully.

本公司所生产与制造的产品都是依据工业环境的标准规格进行,无法产品是被使用在工厂或实验室等场域,我们的品牌就是一个质量保证的象征.客户的满意一向都是本公司所注重的第一优先事项,为确保用户充分的得到本公司的服务与权益,请遵照使用手册上的说明使用本公司的产品

Technical Support (技术支持)

We want you to get the maximum performance from your products. So if you run into technical difficulties, we are here to help. For the most frequently asked questions, you can easily find answers in your product documentation. These answers are normally a lot more detailed than the ones we can give over the phone. So please consult the user's manual first.

To receive the latest version of the user's manual; please visit our Web site at:

<http://www.avalue.com.tw/>

本公司期望客户能够让产品发挥最大化的效能,若您在使用上有任何疑问,可以透过常见问题或是使用手册中得到解答,极大部份的问题都可以透过上述的方式找到答案,或您也可以直接以电话联络我们

最新版本的使用手册可以在以下连结中取得:

<http://www.avalue.com.tw/>

Content 目录

1.	Getting Started 开始使用	8
1.1	Safety Precautions 安全警语	8
1.2	Packing List 包装内容	9
1.3	System Specifications 产品规格	9
1.4	System Overview 系统概况	13
1.4.1	Bottom View 后视图	13
1.5	System Dimensions 系统尺寸	15
2.	Hardware Configuration 硬件配置	16
2.1.1	Serial port connector 1/2/3 (COM) 串行端口 1/2/3(COM)	17
2.1.2	Serial port connector 4 (COM/USB) 串行端口 4(COM/USB)	17
2.3	Motherboard Overviews 主板概述	20
2.4	Motherboard Jumper and Connector list 主板跨接器和连接器列表	21
2.5	Motherboard Jumpers & Connectors settings 主板跨接器和连接器设定	23
2.5.1	Clear CMOS RAM Settings (JBAT) 清除 CMOS RAM 设置(JBAT)	23
2.5.2	ATX Mode/ AT Mode Select (JAT_ATX) ATX/AT 模式选择	23
2.5.3	ME Features Select (JP2) ME 功能选择(JP2)	24
2.5.4	Case Open Message Display Function (COPEN) Case Open 讯息显示功能(COPEN)	24
2.5.5	LVDS Inverter Backlight VCC Select (JP16) LVDS 逆变器背光 VCC 选择	25
2.5.6	LVDS Inverter Header (INVERTER1) LVDS 逆变器接头 (INVERTER1)	25
2.5.7	COM1 Pin9 Function Select (JP12) COM1 Pin9 功能选择 (JP12)	26
2.5.8	COM2 Pin9 Function Select (JP13) COM2 Pin9 功能选择 (JP13)	26
2.5.9	Internal 12V~24V Power Connector (DCIN3) 内部 12V~24V 电源接口 (DCIN3)	27
2.5.10	CPU Fan Connector (CPUFAN) CPU 风扇接口 (CPU FAN)	27
2.5.11	System Fan Connector (SYSFAN) 系统风扇接口 (SYSFAN)	28
2.5.12	SATA III Port connector (SATA1) SATA III 端口连接器 (SATA1)	28
2.5.13	SATA Power Out Connector (PWROUT) SATA 电源输出接口 (PWROUT)	29
2.5.14	Front Panel Header (FP) 前面板插座 (FP)	29
2.5.15	USB 2.0 Port Headers (FP_USB1/FP_USB2) USB 2.0 端口接头 (FP_USB1/FP_USB2) ...	30
2.5.16	USB 2.0 Port Header (FP_USB3) USB 2.0 端口接头 (FP_USB3)	30
2.5.17	PS/2 Keyboard & Mouse Header (PS2KBMS) PS/2 键鼠接口 (PS2KBMS)	31
2.5.18	SMBUS Header (SMBUS) SMBUS 接口	31
2.5.19	Front Panel Audio Header (*FP_AUDIO) 前面板音频接口 (*FP_AUDIO)	32
2.5.20	3W Amplifier Wafer (*SPEAK_CON) 3W 放大器接口 (*SPEAK_CON)	32

2.5.21	RS232 Serial Port Header (COM1/2/3/4) RS232 串口接口 (COM1/2/3/4)	33
2.5.22	GPIO Header (GPIO) GPIO 接口 (GPIO).....	33
2.5.23	LVDS Port Wafer (LVDS) LVDS 接口 (LVDS)	34
2.5.24	LVDS Panel Power VCC Select (JP5) LVDS 面板电源 VCC 选择 (JP5).....	35
2.6	Mounting the system 安装系统 (FPC-1736)	36
2.6.1	Wall Mounting 壁挂安装.....	36
2.6.2	Arm/ Stand Mounting 安装臂/支架	38
2.6.3	Panel Mounting 面板安装.....	39

1. Getting Started 开始使用

1.1 Safety Precautions 安全警语

Warning! 警告!



Always completely disconnect the power cord from your chassis whenever you work with the hardware. Do not make connections while the power is on. Sensitive electronic components can be damaged by sudden power surges. Only experienced electronics personnel should open the PC chassis.

拆装硬件时，请事先确认已关机并移除外部输入之电源。系统开机的状态下切勿做任何连结。突如其来的电涌可能会造成电子零件的毁损。若需打开机器的外壳，请联络并交由专业的技术员操作。

Caution!



Always ground yourself to remove any static charge before touching the CPU card. Modern electronic devices are very sensitive to static electric charges. As a safety precaution, use a grounding wrist strap at all times. Place all electronic components in a static-dissipative surface or static-shielded bag when they are not in the chassis.

Risk of Explosion if Battery is replaced by an Incorrect Type. Dispose of Used Batteries According to the Instructions.

接触 **CPU** 板时，请确实接地以避免静电的产生。现代的电子仪器对于静电相当敏感，为了人员的安全，在操作的过程中请随时配戴防静电手环。从机器中移除的电子零件，请放置于防静电表面或存放于抗静电袋中

如果更换电池类型不正确，则存在爆炸风险。按照说明处理

Français:

电池

Attention!



Débranchez le câble d'alimentation de votre châssis chaque fois que vous travaillez avec le matériel. Ne faites pas de connexion lorsque le système est allumé. Les composants électroniques sensibles peuvent être endommagés par les surtensions soudaines. Seule les personnels expérimentés de l'électronique peuvent ouvrir le châssis du PC.

Précaution!



Il faut toujours mettre à la masse pour éliminer l'électricité statique avant de toucher la carte CPU. Les appareils électroniques modernes sont très sensibles aux électricité statique. Pour des raisons de sécurité, utilisez un bracelet électrostatique. Placez tous les composants électroniques sur une surface antistatique ou dans un sac antistatique quand ils ne sont pas dans le châssis. Risque d'explosion si la batterie est remplacée par un type incorrect. Jetez les piles usagées selon les instructions

1.2 Packing List 包装内容

- 1 x FPC-1736 Panel PC 1x FPC-1736 平板计算机
- 1 x Power Adapter 1x 电源适配器
- 4 x screws for VESA 4x VESA 安装螺丝
- 8 x screws for HDD 8x 硬盘安装螺丝

1.3 System Specifications 产品规格

Component 组件	
CPU 中央处理器	Intel® LGA1151 Socket Supports 8th /9th refresh Generation Core™ Pentium® /i7/ i5/ i3 Processors (Max. TDP at 65W)
CPU Cooler (Type) 散热器	Fan design
Memory 内存	2* 260-pin DDR4 2666 MHz SO-DIMM socket, supports up to 64GB Max
Adapter 电源适配器	ACC-ADP-120N-10R
System Fan 系统风扇	Fan design, 12V, 60 x 60 x 25mm, D4P, 300mm, 7600RPM
Speaker 喇叭	5W x 2
Wireless LAN 无线网络	IEEE802.11 ax/ac/a/b/g/n 2.4 GHz, 5 GHz, 6 GHz (optional)
Bluetooth 蓝牙	BT5.2 (optional)
Operating System 操作系统	Win10 64bit, Linux
Expansion Card 扩展槽	*1 x M.2 E-Key, support Wi-Fi module (optional)
Storage	
Solid State Drive 固态硬盘	1 x SATA III for SSD expansion (Reserve space for 1 x 2.5" Drive Bay design)
Other Storage Device	1 x M.2 M-key slot 2242 support SATA interface

FPC-1736

其它硬盘装置	
Panel	
LCD Panel 屏幕型号	17" 1280*1024 250NITS
LCD Control Board 屏幕控制器	Built-in
B/L Inverter/Converter 背光控制器	External
Touch Screen 触控屏幕	17" PCAP Touch
Touch Controller 触控控制器	ILITEK
External I/O	
Serial Port 串行端口	RS232*4 (Optional)
USB Port USB 埠	4 x USB 3.0 1 x USB 2.0 for USB dongle in the enclosure 3 x USB 2.0 (Optional)
DIO Port DIO 端口	1 x 8-bit GPIO
Video Port 视讯端口	1 x HDMI 1.4B 1 x VGA *Support one type of video function at a time
Audio Port 音讯端口	1 x Line-out, 1 x Mic-in
LAN Port 网络端口	1 x Intel i219-V Gigabit Ethernet 1 x Intel i225-V 2.5 Gigabit Ethernet
Wireless LAN Antenna 无线天线	WIFI 6E 2.4GHz~7.1GHz Antenna (optional)
Switch 按键	Yes and option for 2 pin phoenix power switch
Expansion Slots 扩展槽	1 x PCI-ex4
Mechanical 机构	
Power Type 电源输入	12~24V DC-in

Power Connector Type 电源输入格式	DC Jack and 2 pin phoenix power connection *Only can use one type of connector at the same time
Dimension 尺寸	392.72 x 325.32 x 121.55 mm
Weight 重量	7.5 Kg
Color 颜色	Black
Fanless 无风扇	No
OS Support 操作系统	Windows 10 64bits, Linux
Reliability 可靠性	
EMI Test 电磁干扰测试	CE/FCC Class A/CCC
Vibration Test 震动测试	<p>Random Vibration Operation</p> <p>1 Test PSD : 0.00454G²/Hz , 1.5 Grms</p> <p>2 System condition : operation mode</p> <p>3 Test frequency : 5~500 Hz</p> <p>4 Test axis : X,Y and Z axis</p> <p>5 Test time : 30 minutes per each axis</p> <p>6 IEC60068-2-64 Test Fh</p> <p>6 Storage : mSATA</p> <p>Sine Vibration test (Non-operation)</p> <p>1 Test Acceleration : 2G</p> <p>2 Test frequency : 5~500 Hz</p> <p>3 Sweep : 1 Oct/ per one minute. (logarithmic)</p> <p>4 Test Axis : X,Y and Z axis</p> <p>5 Test time :30 min. each axis</p> <p>6 System condition : Non-Operating mode</p> <p>7. Reference IEC 60068-2-6 Testing procedures</p> <p>Package Vibration Test:</p> <p>1 Test PSD : 0.026G²/Hz , 2.16 Grms</p> <p>2 Test frequency : 5~500 Hz</p> <p>3 Test axis : X,Y and Z axis</p> <p>4 Test time : 30 minutes per each axis</p> <p>5 IEC 60068-2-64 Test Fh</p>
Mechanical Shock Test 机械冲击测试	<p>1 Wave from : Half Sine wave</p> <p>2 Acceleration Rate : 10g for operation mode</p> <p>3 Duration Time : 11ms</p> <p>4 No. of shock : Z axis 300 times</p>

FPC-1736

	5 Test Axis : Z axis 6 operation mode 7 Reference IEC 60068-2-27 testing procedures Test Eb : Shock Test
Drop Test 落摔测试	Package drop test Reference ISTA 2A, Method : IEC-60068-2-32 Test:Ed Test Ea : Drop Test 1 Test phase : One corner, three edges, six faces 2 Test high : 96.5cm 3 Package weight : 7.5 Kg 4 Test drawing
Operating Temperature 操作温度	0 ~ 45°C *Air flow=0.7 m/s
Operating Humidity 操作湿度	40°C @ 95% Relative Humidity, Non-condensing
Storage Temperature 储存湿度	-20°C ~ 60°C
Power Consumption 电源功耗	Max. load 101.21 W with intel core i7-9700E/4GB/64GB(M.2 SSD)/64BG(2.5" SSD), DC-in 19V

*以上规格可能会依制造情况而有变动



Note: Specifications are subject to change without notice. (备注：规格如有更改，恕不另行通知)

1.4 System Overview 系统概况

1.4.1 Bottom View 后视图

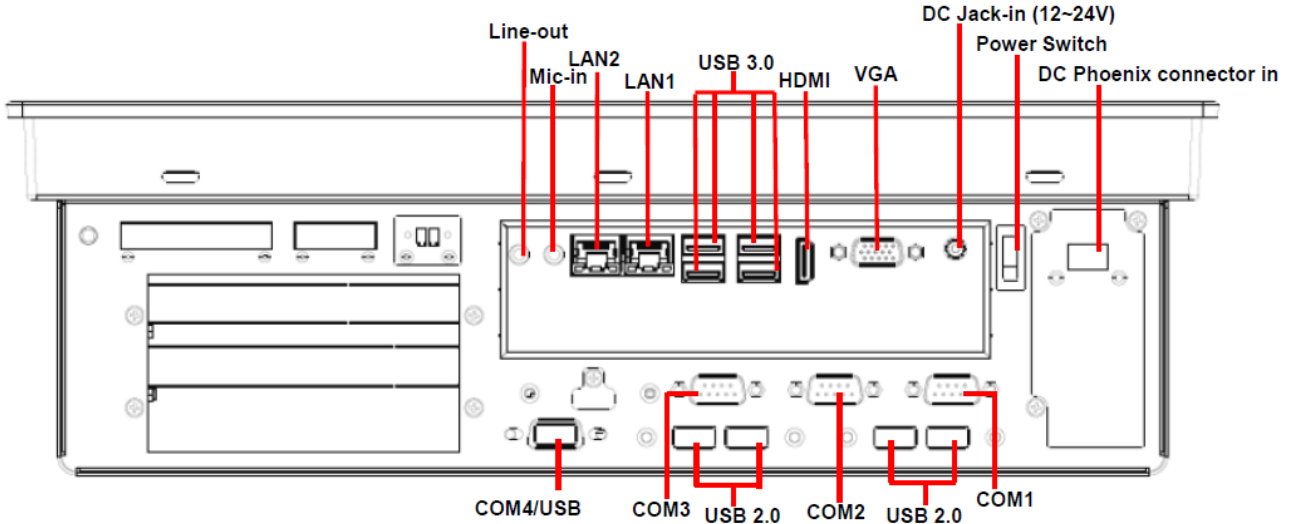

Connectors 连接器

Label 标签	Function 功能	Note 备注
Power Switch 电源开关	Power on button 开机按钮	
DC Jack-in (12~24V) 直流电源插孔 (12~24V)	DC power-in connector 直流电源输入连接器	
DC Phoenix connector in 直流电源凤凰连接器	DC power-in connector 直流电源输入连接器	
COM1/2/3	Serial port connector 1/2/3 串行端口 1/2/3	
COM4/USB	Serial port connector 4 串行端口 4	USB 2.0 connector (Optional) USB 2.0 连接器 (可选) Foreseen hole(Default) 预见不断孔 (默认)
Line-out 音源输出	Line-out audio jack (Optional) 输出音频插孔 (可选)	
Mic-in 麦克风接口	Mic-in audio jack (Optional) 麦克风输入音频插孔 (可选)	
USB 3.0	4 x USB 3.0 connector	

FPC-1736

	4 x USB 3.0 接口
USB 2.0	1 x USB 2.0 for USB dongle in the enclosure 1 x USB 2.0 用於機殼內的 USB 擴充 3 x USB 2.0 (Optional) 3 x USB 2.0 (可選)
LAN1	RJ-45 Ethernet connector 1 以太网连接器1
LAN2	RJ-45 Ethernet connector 2 以太网连接器2
VGA	VGA connector VGA连接器
HDMI	HDMI connector HDMI连接器

1.5 System Dimensions 系统尺寸

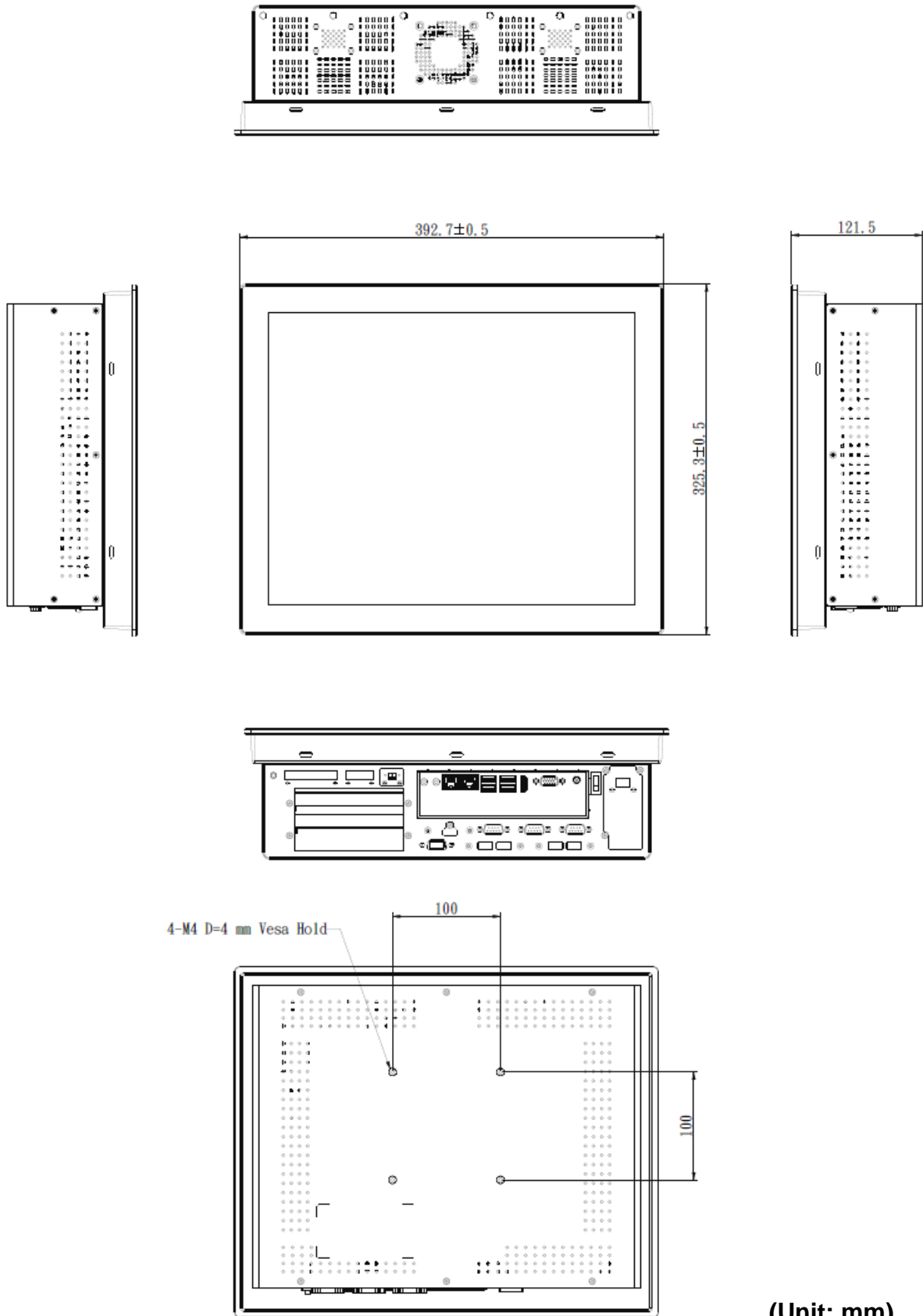

(Unit: mm)
(单位: mm)

2. Hardware Configuration 硬件配置



Note: If you need more information, please visit our website:

<http://www.avalue.com.tw>

备注：若需要更多资讯，请造访我们的网站

<http://www.avalue.com.tw>

2.1 FPC-1736 connector mapping 连接器定义

2.1.1 Serial port connector 1/2/3 (COM) 串行端口 1/2/3(COM)

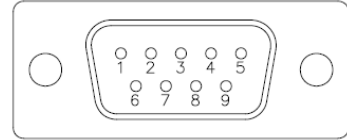
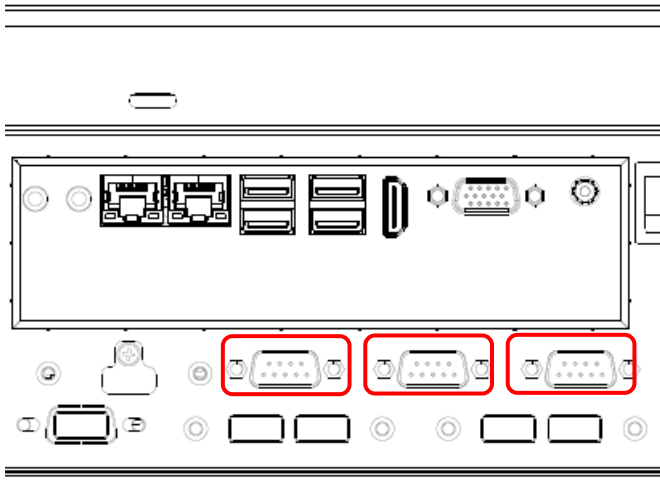

Signal	PIN	PIN	Signal
DCD	1	6	DSR
RXD	2	7	RTS
TXD	3	8	CTS
DTR	4	9	RI
GND	5		

2.1.2 Serial port connector 4 (COM/USB) 串行端口 4(COM/USB)

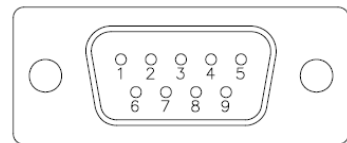
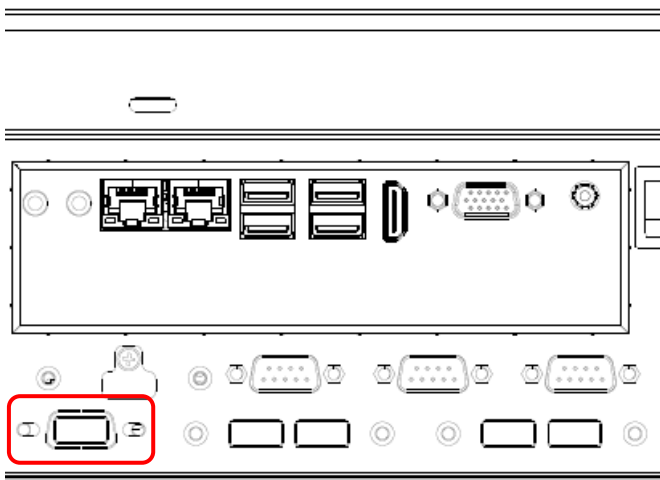

Signal	PIN	PIN	Signal
DCD	1	6	DSR
RXD	2	7	RTS
TXD	3	8	CTS
DTR	4	9	RI
GND	5		

2.2 Installing PCIe devices (FPC-1736) 安装 PCIe 设备 (FPC-1736)

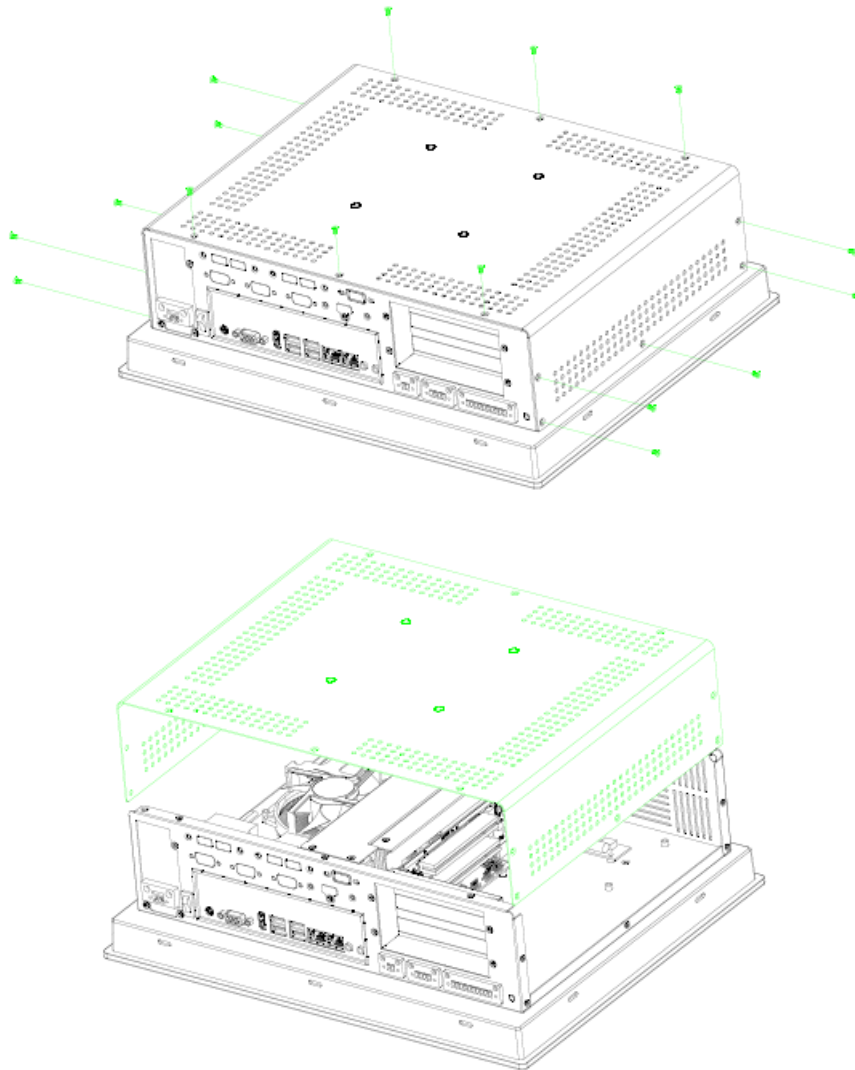

Step 1. Remove 16 screws to release the chassis cover, and remove it.

步骤 1. 卸下 16 颗螺丝以松开机箱盖，并将其取下

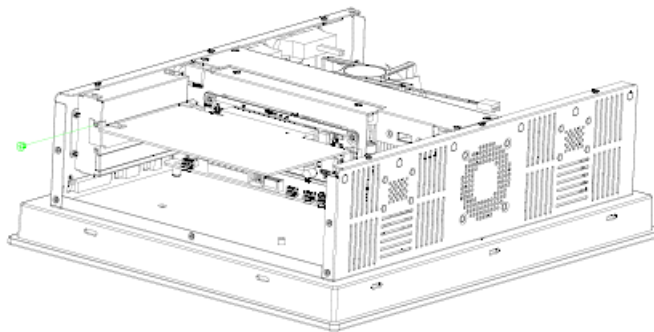
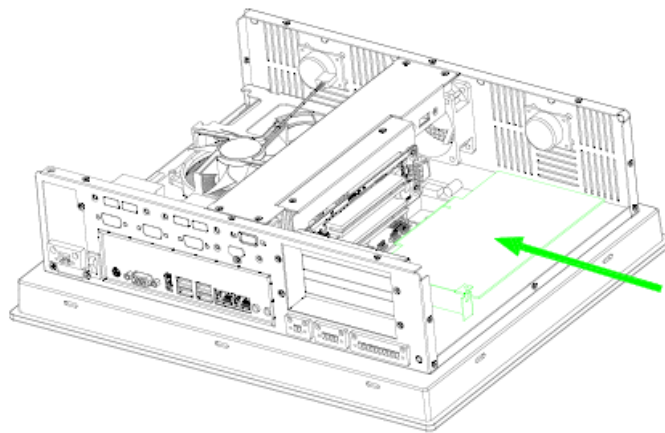
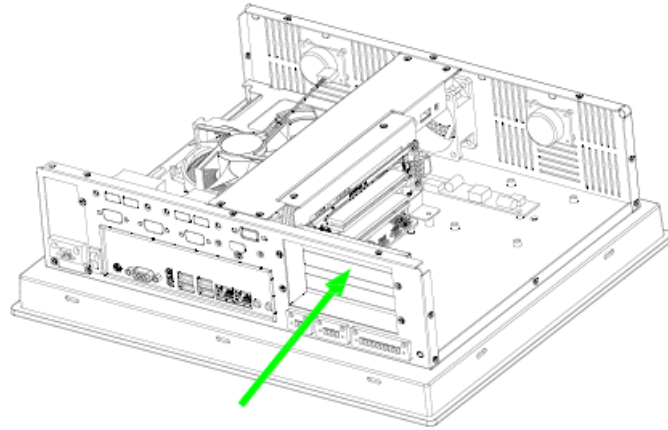

Step 2. Install the expansion module and fasten screw.

步骤 2. 安装扩展模块并拧紧螺丝。

2.3 Motherboard Overviews 主板概述

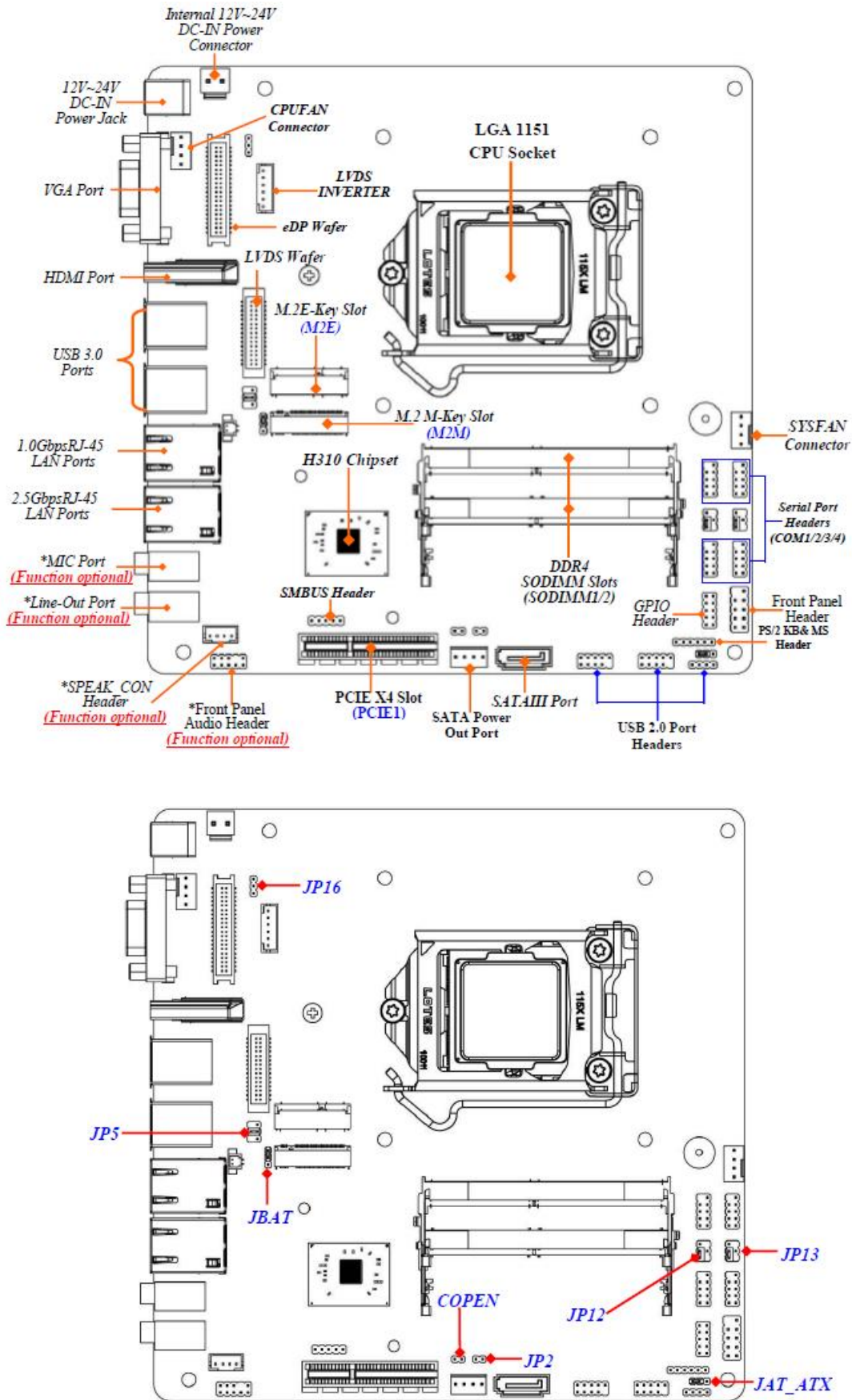

2.4 Motherboard Jumper and Connector list 主板跨接器和连接器列表

Jumper跨接器

Label标签	Function功能	Note备注
JBAT	Clear CMOS RAM Settings 清除 CMOS RAM 设置	3 x 1 header, pitch 2.00mm
JAT_ATX	ATX/AT Mode Select ATX/AT 模式选择	3 x 1 header, pitch 2.00mm
JP2	ME Features Select ME 功能选择	2 x 1 header, pitch 2.00mm
COPEN	Case Open Message Display Function Case Open 讯息显示功能	2 x 1 header, pitch 2.00mm
JP5	Panel Power VCC Select 面板电源 VCC 选择	3 x 2 header, pitch 2.00mm
JP16	Inverter Backlight VCC Select 逆变器背光 VCC 选择	2 x 1 header, pitch 2.00mm
JP12	COM1 Port Pin9 Function Select COM1 端口 Pin9 功能选择	3 x 2 header, pitch 2.00mm
JP13	COM2 Port Pin9 Function Select COM2 端口 Pin9 功能选择	3 x 2 header, pitch 2.00mm

Connectors

Label标签	Function功能	Note备注
DCIN1	12V~24V DC-in Power Jack 12V~24V DC-in 电源插座	
VGA	VGA Port Connector VGA 端口连接器	
HDMI	HDMI Port Connector HDMI 端口连接器	
USB1/USB2	USB 3.0 Port Connector X4 USB 3.0 接口连接器 X4	
LAN1	1.0Gbps RJ-45 LAN Connector 1.0Gbps RJ-45 区域网连接器	
LAN 2	2.5Gbps RJ-45 LAN Connector 2.5Gbps RJ-45 区域网连接器	
*HMIC	Audio MIC Connector 音频麦克风连接器	

FPC-1736

*HOUT	Audio Line-out Connector 音频输出连接器	
DCIN3	Internal 12V~24V DC-in Power Connector 内部 12V~24V DC-in 电源连接器	
SATA1	SATAIII Connector SATAIII 连接器	
PWROUT	SATA Power-out Connector SATA 电源输出连接器	
CPUFAN	CPUFAN Connector CPU 风扇连接器	
SYSFAN	System Fan Connector 系统风扇接口	
FP	Front Panel Header(PWR LED/ HD LED/Power Button /Reset) 前面板接头连接器 (电源 LED/ 硬盘 LED/电 源按钮/复位)	2 x 5 header, pitch 2.54mm
FP_USB1/ FP_USB2	USB 2.0 Port Headers USB 2.0 端口接头	2 x 5 header, pitch 2.00mm
FP_USB3	USB 2.0 Port Header USB 2.0 端口接头	4 x 1 header, pitch 2.00mm
PS2KBMS	PS/2 Keyboard & Mouse Header PS/2 键盘和鼠标接头	6 x 1 header, pitch 2.00mm
SMBUS	SMBUS Header SMBUS 接头	5 x 1 header, pitch 2.00mm
*FP_AUDIO	Front Panel Audio Header 前面板音频接头	2 x 5 header, pitch 2.00mm
*SPEAK_CON	3W Amplifier Wafer 3W 音讯放大器	4 x 1 wafer, pitch 2.00mm
COM1/2/3/4	RS232 Serial Port Headers RS232 串口接头	2 x 5 header, pitch 2.00mm
GPIO	GPIO Port Header GPIO 端口接头	2 x 5 header, pitch 2.54mm
LVDS	LVDS Port Wafer LVDS 端口接头	2 x 15 wafer, pitch 1.25mm
INVERTER1	LVDS Inverter Wafer LVDS 逆变器接头	6 x 1 wafer, pitch 2.00mm
eDP	eDP Port Wafer eDP 端口接头	2 x 15 wafer, pitch 1.25mm

2.5 Motherboard Jumpers & Connectors settings 主板跨接器和连接器设定

2.5.1 Clear CMOS RAM Settings (JBAT) 清除 CMOS RAM 设置(JBAT)

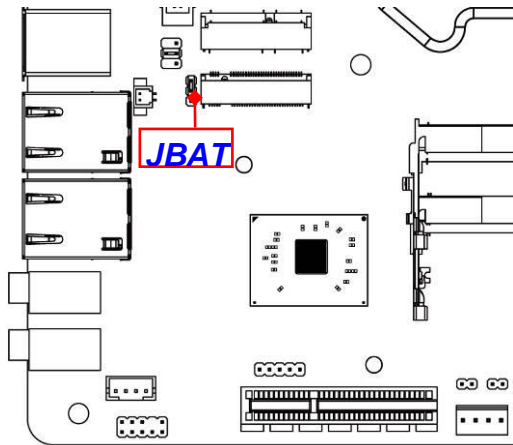

* Default

JBAT→Clear CMOS(清除 CMOS)

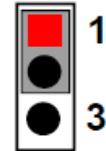

1-2 Closed 1-2 关闭:

Normal(Default)* (正常 (默认))*

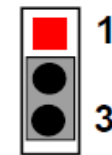

2-3 Closed 2-3 关闭:

Clear CMOS Settings(清除 CMOS 设置)

2.5.2 ATX Mode/ AT Mode Select (JAT_ATX) ATX/AT 模式选择

JAT_ATX→ATX/AT Mode Select(ATX/AT 模式选择)

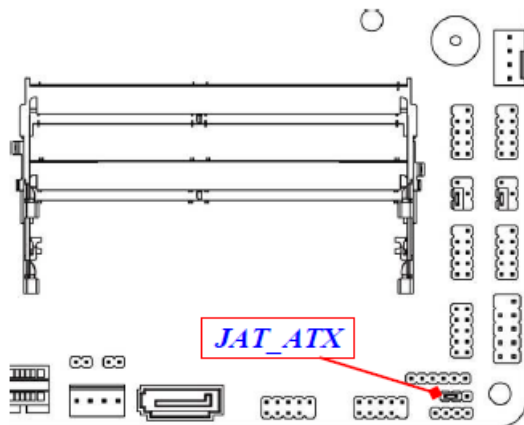

* Default

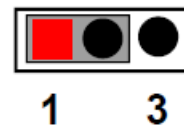

1-2 Closed 1-2 关闭:

ATX Mode Selected(Default)*

已选择 ATX 模式 (默认)*

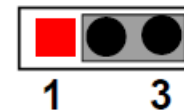

2-3 Closed 2-3 关闭:

AT Mode Selected AT 模式选择

***ATX Mode Selected:** Press power button to power on after power input ready;

AT Mode Selected: Directly power on as power input ready.

*选择 ATX 模式: 电源输入准备就绪后按电源键开机;

AT Mode Selected: 当电源输入就绪时直接开机。

2.5.3 ME Features Select (JP2) ME 功能选择(JP2)

JP2→ME Features Select ME 功能选择

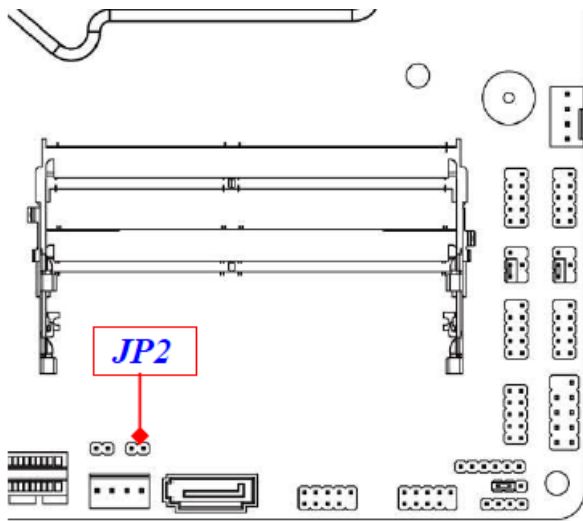

* Default 默认



Pin1

1-2 Open 1-2 打开:

Enable ME Features*启用 ME 功能*



Pin1

1-2 Closed 1-2 关闭:

Disable ME Features 关闭 ME 功能

2.5.4 Case Open Message Display Function (COPEN) Case Open 讯息显示功能 (COPEN)

COPEN→Case Open Detection Case Open 侦测

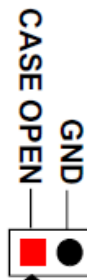
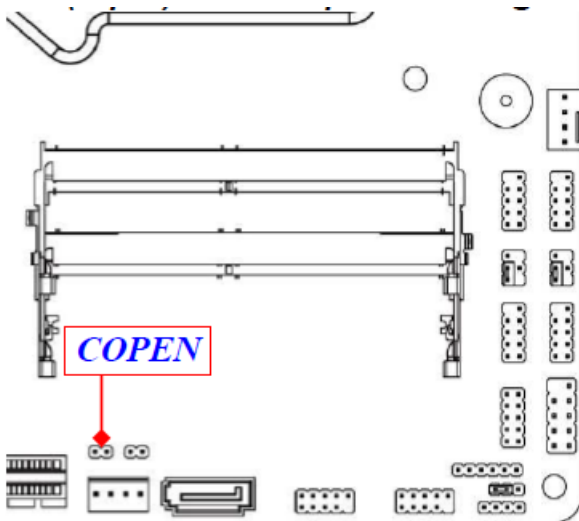

Pin1

Pin 1-2 Short: When Case open function pin short to GND, the Case open function was detected. When Used, needs to enter BIOS and enable 'Case Open Detect' function. In this case if your case is removed, next time when you restart your computer, a message will be displayed on screen to inform you of this.

Pin 1-2 关闭: 当 Case open 功能引脚短接 GND 时, 侦测到 Case open 功能。使用时, 需要进入 BIOS 并启用 “Case Open 侦测”功能。在这种情况下, 如果您的机箱被移动, 下次您重新启动计算机时, 屏幕上会显示一条消息来通知您。

2.5.5 LVDS Inverter Backlight VCC Select (JP16) LVDS 逆变器背光 VCC 选择

JP16→LVDS INVERTER Backlight VCC

LVDS 逆变器背光 VCC

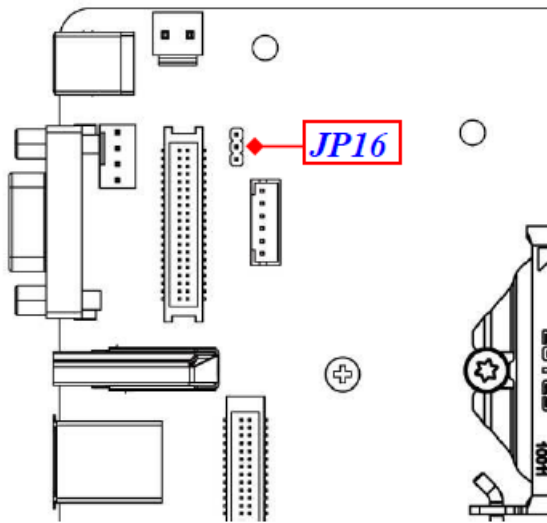

* Default 默认

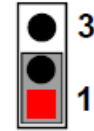

1-2 Closed 1-2 关闭:

Inverter backlight VCC=5V 逆变器背光 VCC=5V

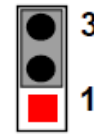

2-3 Closed 2-3 关闭:

Inverter backlight VCC=12V* 逆变器背光

VCC=12V*

2.5.6 LVDS Inverter Header (INVERTER1) LVDS 逆变器接头 (INVERTER1)

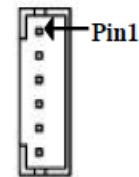
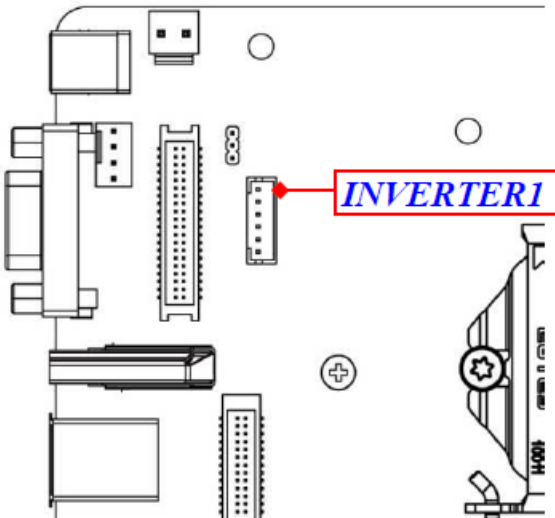

Signal	PIN
BKLT_PWR1	1
BKLT_PWR2	2
BKLT_EN	3
BKLT_PWM	4
GND1	5
GND2	6

Warning! Find Pin-1 location of the inverter and make sure that the installation direction is correct! Otherwise serious harm will occur to the board/display panel!!

警告！找到逆变器的 Pin-1 位置，确保安装方向正确！否则会对板/显示面板造成严重伤害！！

2.5.7 COM1 Pin9 Function Select (JP12) COM1 Pin9 功能选择 (JP12)

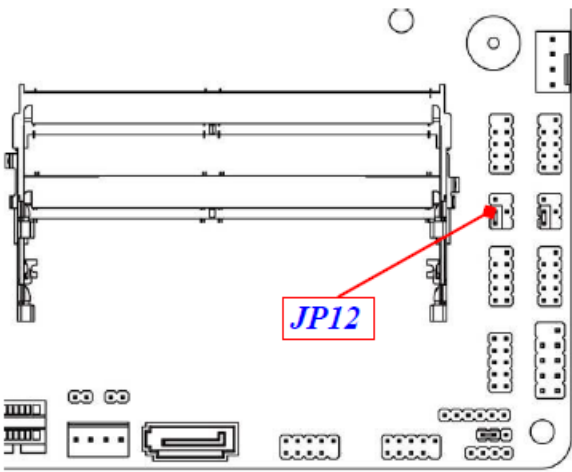

JP12→COM1 Pin9 Function Select

COM1 Pin9 功能选择

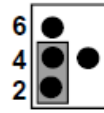

2-4 Closed* 2-4 关闭:*

Pin9=RS232,Ring

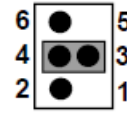

3-4 Closed 3-4 关闭:

Pin9=5V

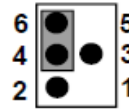

6-4 Closed 6-4 关闭:

Pin9=12V

* Default 默认

2.5.8 COM2 Pin9 Function Select (JP13) COM2 Pin9 功能选择 (JP13)

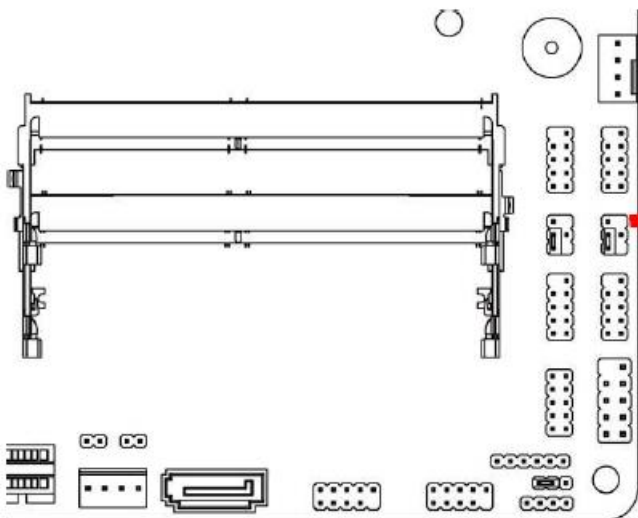

JP13→COM2 Pin9 Function Select

COM2 Pin9 功能选择

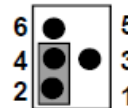

2-4 Closed:*

2-4 关闭:*

Pin9=RS232,Ring

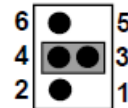

3-4Closed:

3-4 关闭:

Pin9=5V

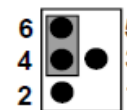

6-4 Closed6-4 关闭:

Pin9=12V

* Default 默认

2.5.9 Internal 12V~24V Power Connector (DCIN3) 内部 12V~24V 电源接口 (DCIN3)

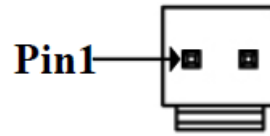
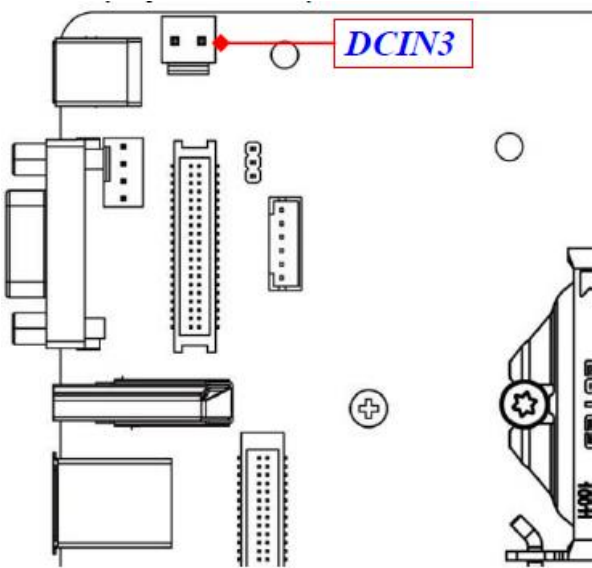

Signal	PIN
+12V~24V	1
GND	2

Warning: Find Pin-1 position before connecting power cable to this 2-pin power connector. **WRONG INSTALLATION DIRECTION WILL DAMAGE THE BOARD!!**

警告：在将电源线连接到此电源连接器之前，先找到 Pin-1 位置。错误的安装方向会损坏电路板！！

2.5.10 CPU Fan Connector (CPUFAN) CPU 风扇接口 (CPU FAN)

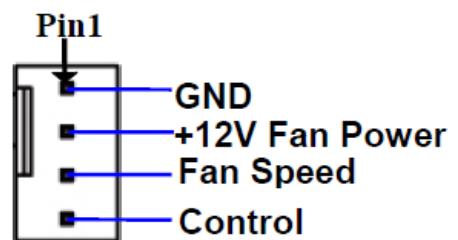
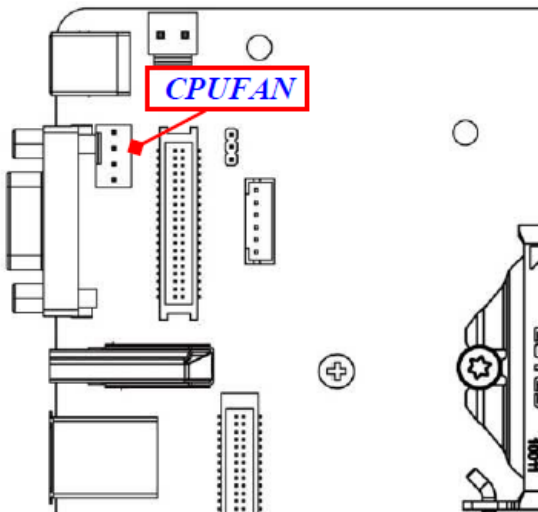

2.5.11 System Fan Connector (SYSFAN) 系统风扇接口 (SYSFAN)

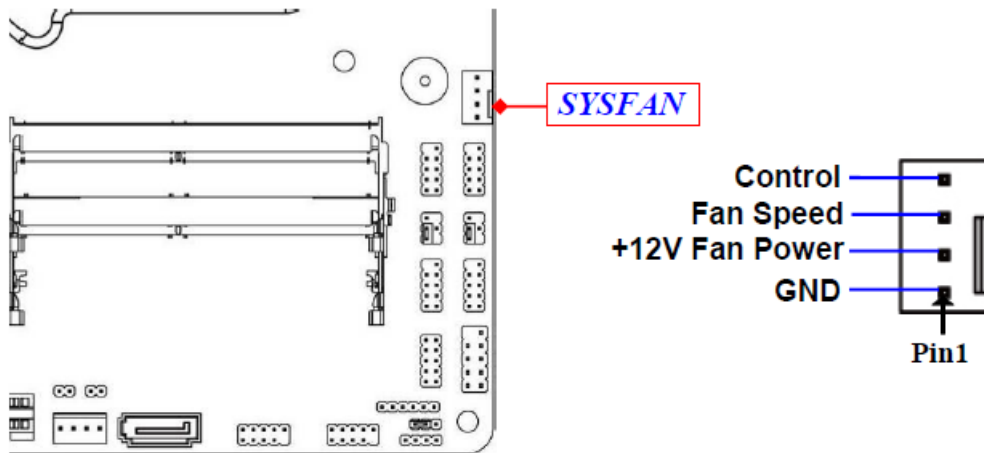

2.5.12 SATA III Port connector (SATA1) SATA III 端口连接器 (SATA1)

SATA1 is a high-speed SATAIII port that supports 6GB/s transfer rate.

SATA1 是高速 SATAIII 接口，支持 6GB/s 的传输速率。

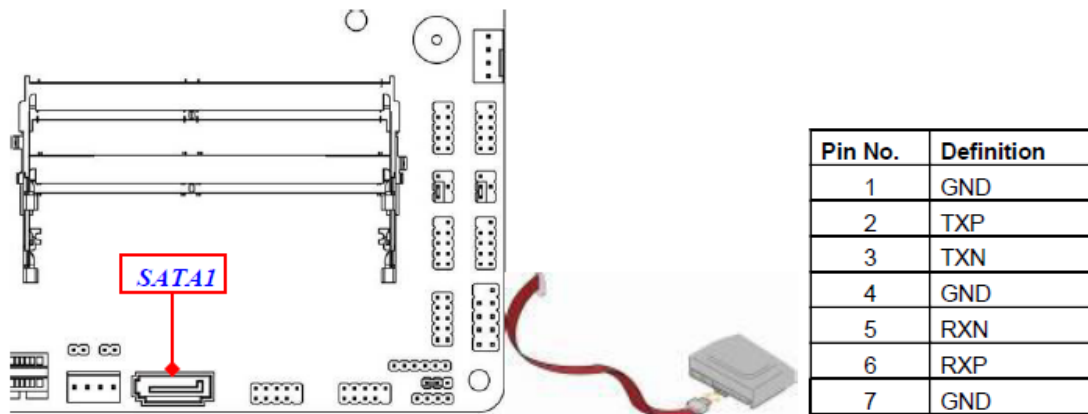

2.5.13 SATA Power Out Connector (PWROUT) SATA 电源输出接口 (PWROUT)

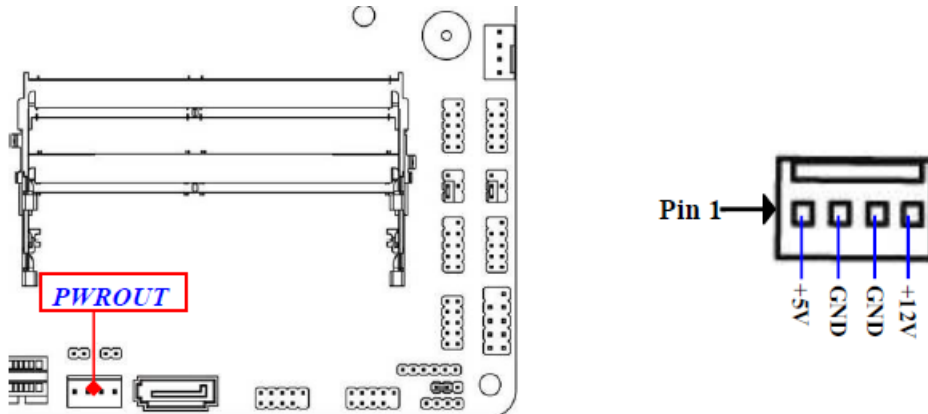

Warning: Make sure that Pin-1 of compatible SATA Power connector is inserted into corresponding Pin-1 of SATAPW to avoid possible damage to the board and hard disk driver!

警告：确保兼容的 SATA 电源连接器的 Pin-1 插入到 SATAPW 的相应 Pin-1，以避免可能损坏主板和硬盘驱动器！

2.5.14 Front Panel Header (FP) 前面板插座 (FP)

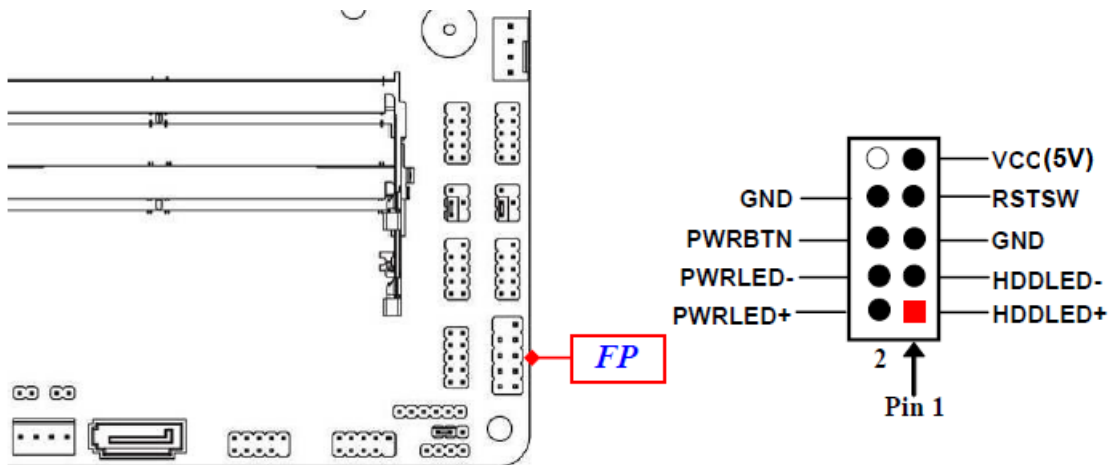

2.5.15 USB 2.0 Port Headers (FP_USB1/FP_USB2) USB 2.0 端口接头 (FP_USB1/FP_USB2)

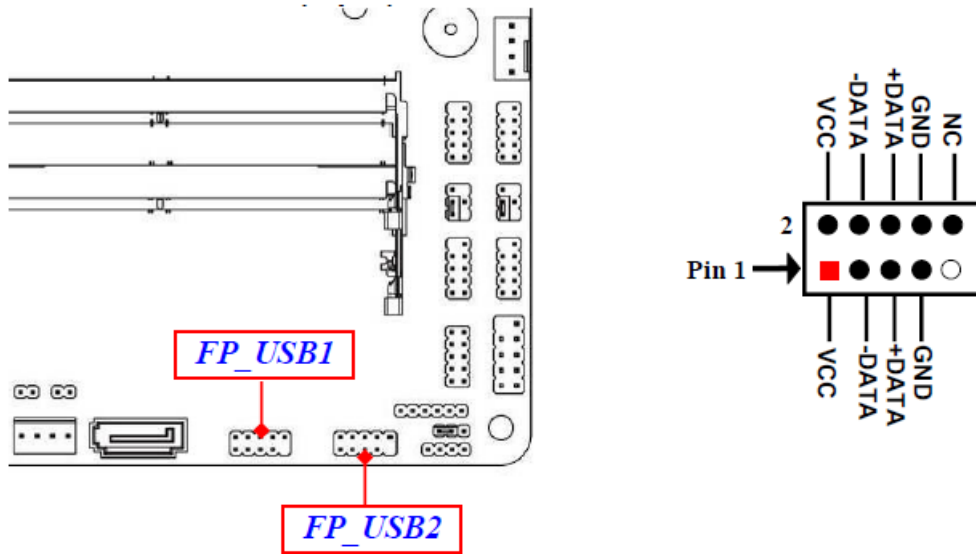

2.5.16 USB 2.0 Port Header (FP_USB3) USB 2.0 端口接头 (FP_USB3)

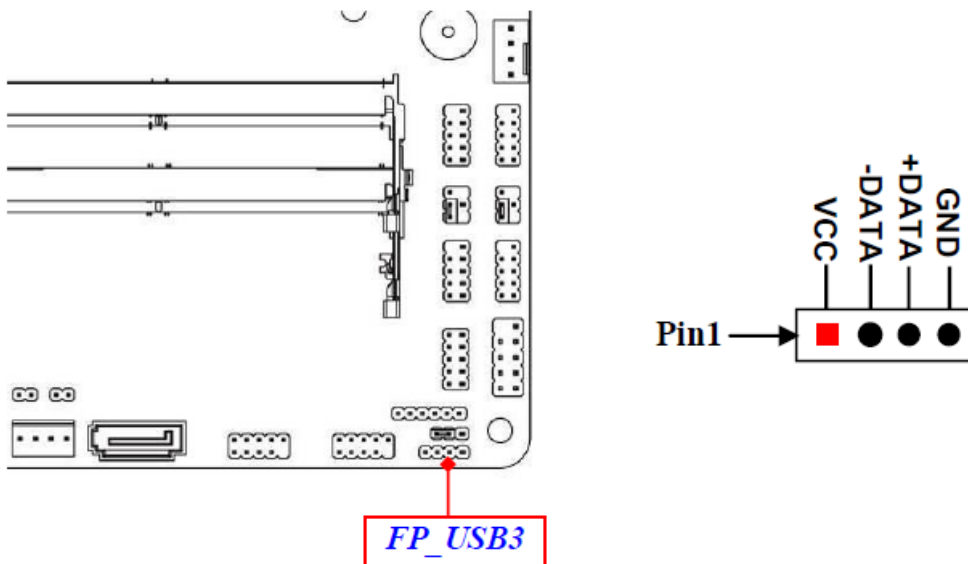

2.5.17 PS/2 Keyboard & Mouse Header (PS2KBMS) PS/2 键鼠接口 (PS2KBMS)

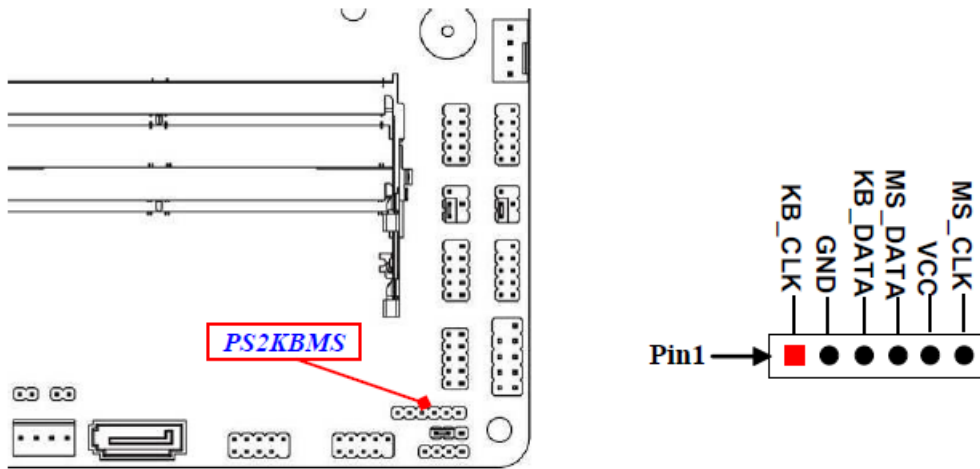

2.5.18 SMBUS Header (SMBUS)月 SMBUS 接口

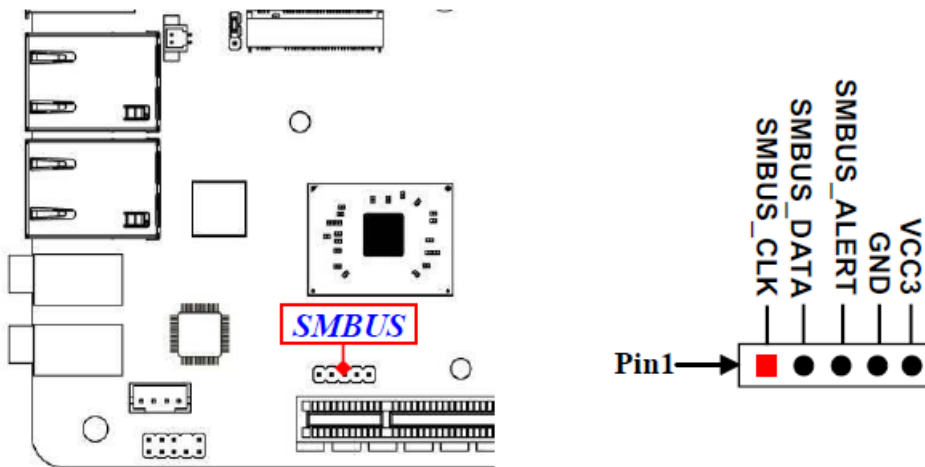

2.5.19 Front Panel Audio Header (*FP_AUDIO) 前面板音频接口 (*FP_AUDIO)

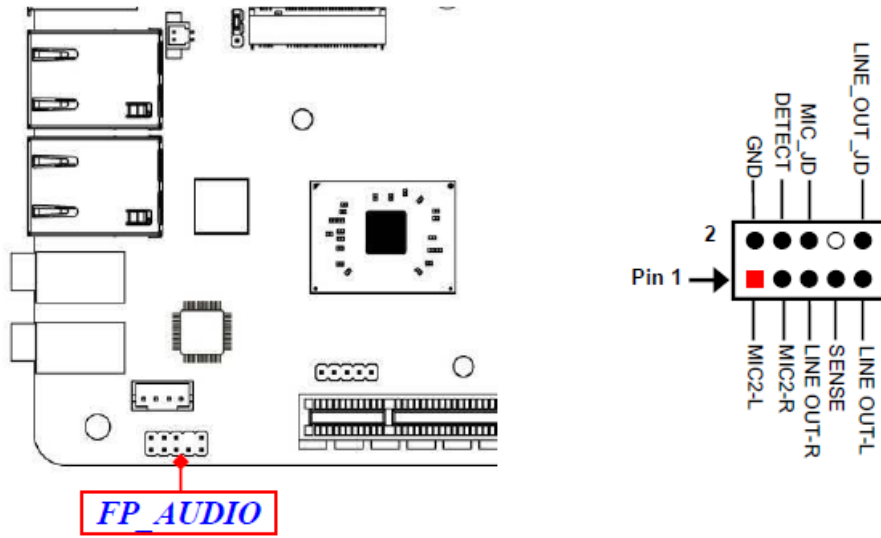

2.5.20 3W Amplifier Wafer (*SPEAK_CON) 3W 放大器接口 (*SPEAK_CON)

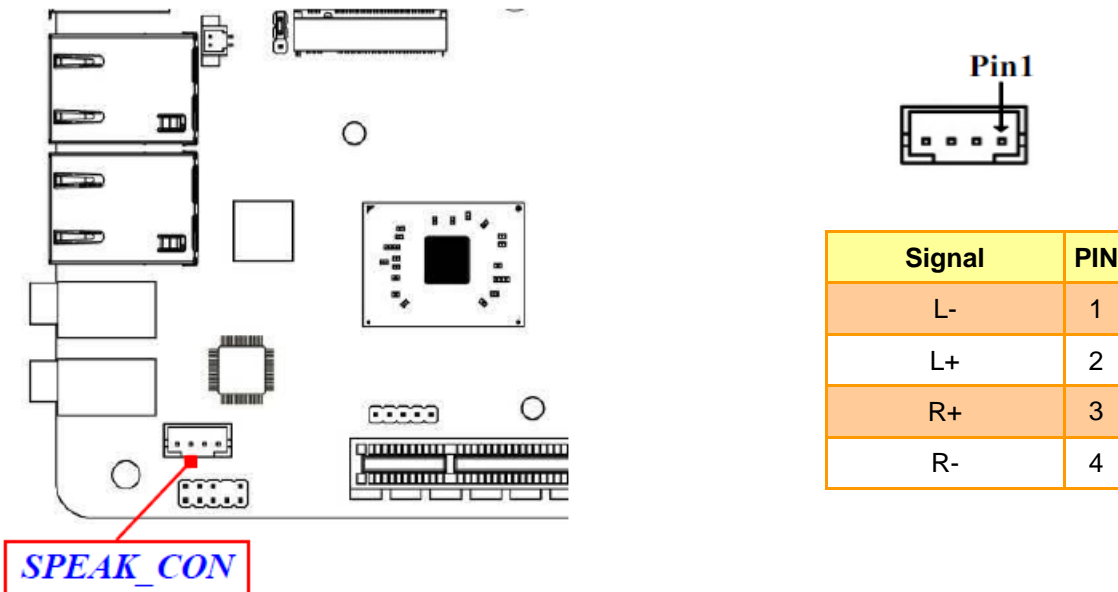

2.5.21 RS232 Serial Port Header (COM1/2/3/4) RS232 串口接口 (COM1/2/3/4)

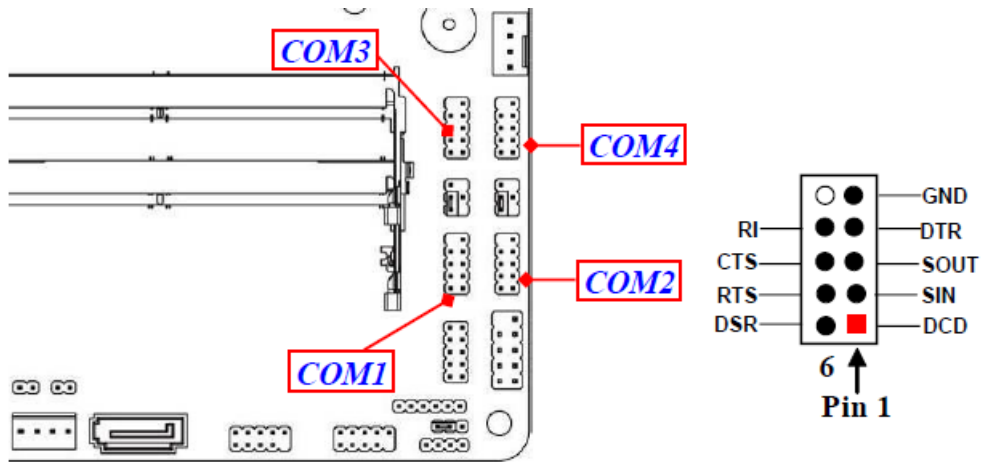

2.5.22 GPIO Header (GPIO) GPIO 接口 (GPIO)

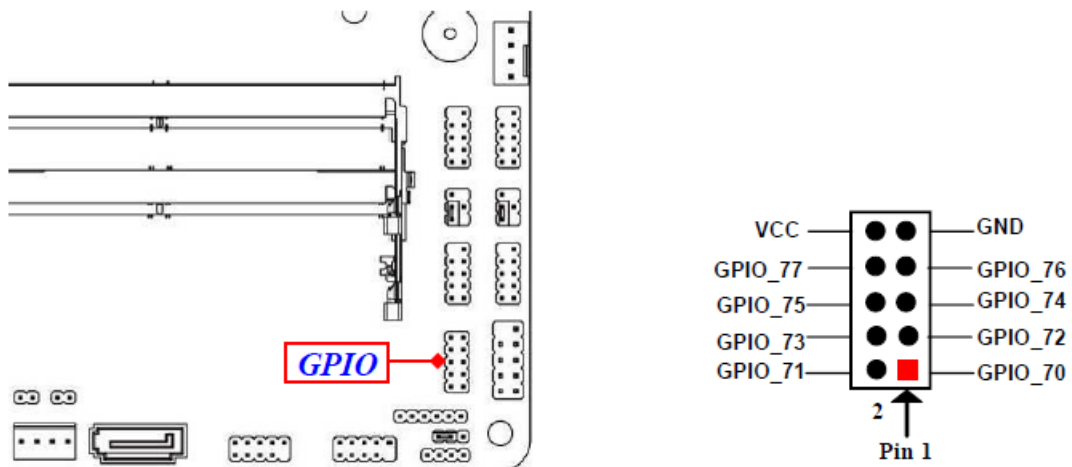

2.5.23 LVDS Port Wafer (LVDS) LVDS 接口 (LVDS)

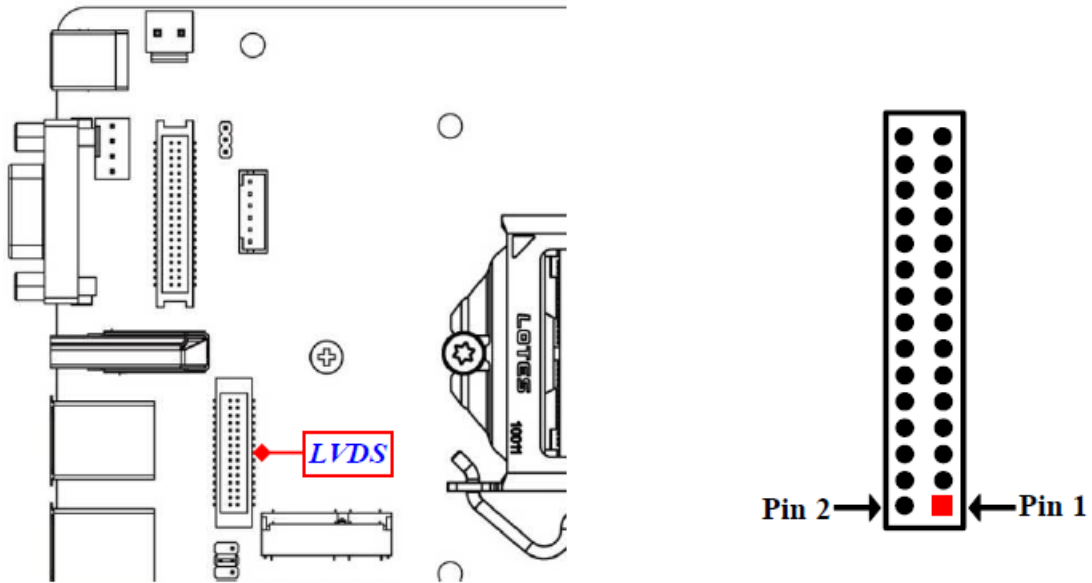

Signal	PIN	PIN	Signal
PVCC	30	29	PVCC
PVCC	28	27	PVCC
LVDSA_DATAN0	26	25	LVDSA_DATAP0
LVDSA_DATAN1	24	23	LVDSA_DATAP1
LVDSA_DATAN2	22	21	LVDSA_DATAP2
LVDS_CLKAN	20	19	LVDS_CLKAP
LVDSA_DATAN3	18	17	LVDSA_DATAP3
GND	16	15	GND
GND	14	13	GND
NC/DDC_CLK	12	11	NC/DDC_DATA
LVDSB_DATAP0	10	9	LVDSB_DATAN0
LVDSB_DATAP1	8	7	LVDSB_DATAN1
LVDSB_DATAP2	6	5	LVDSB_DATAN2
LVDS_CLKBP	4	3	LVDS_CLKBN
LVDSB_DATAP3	2	1	LVDSB_DATAN3

2.5.24 LVDS Panel Power VCC Select (JP5) LVDS 面板电源 VCC 选择 (JP5)

JP5→LVDS Panel Power VCC Select

LVDS 面板电源 VCC 选择

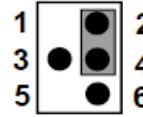
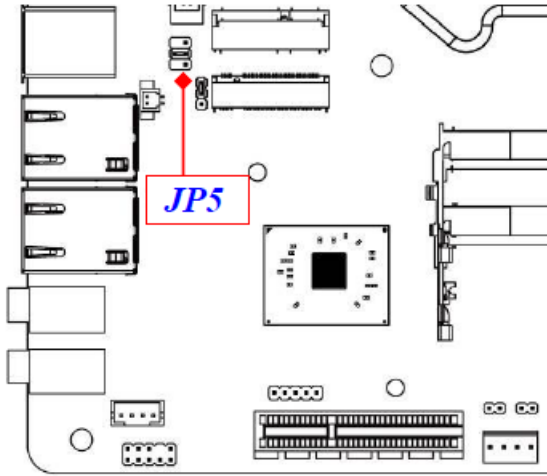

2-4 Closed 2-4 关闭:
VCC=3.3V;

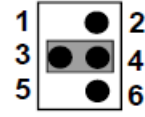

3-4 Closed* 3-4 关闭:*
VCC=5V;

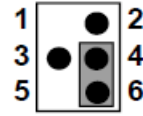

6-4 Closed 6-4 关闭:
VCC=12V.

* Default 默认

2.6 Mounting the system 安装系统 (FPC-1736)

The panel PC supports various mounting options, as listed below.

此平板计算器支持多种安装选项，如下所列

- Wall mounting 壁挂安装
- Arm/ Stand mounting 安装臂/支架
- Panel mounting 面板安装

2.6.1 Wall Mounting 壁挂安装

To mount the panel PC onto wall, follow the instruction below (see Figure for addition reference).

要将平板计算器安装到墙上，请按照以下说明进行操作（请参见图了解更多信息）

1. Insert four M4 screws into the VESA holes on the panel PC and tighten them to secure the bracket to the rear panel, ensure that the thread depth of the screws on the rear panel does not exceed 4mm

将四颗 M4 螺丝插入平板计算器的 VESA 孔并拧紧，将支架固定在后面板，确保后面板螺丝的螺纹深度不超过 4mm

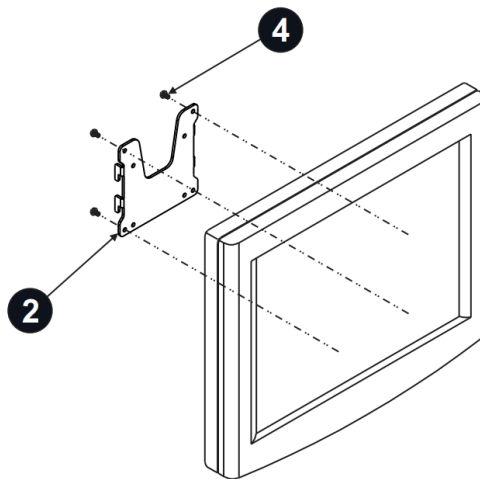

- Select the location on the wall for the wall mount plate, secure the mount plate to the wall by inserting four M5 screws into pilot holes and tightening them.

选择壁挂板在墙上的位置，将四颗 M5 螺钉插入定位孔并拧紧，将安装板固定到墙上

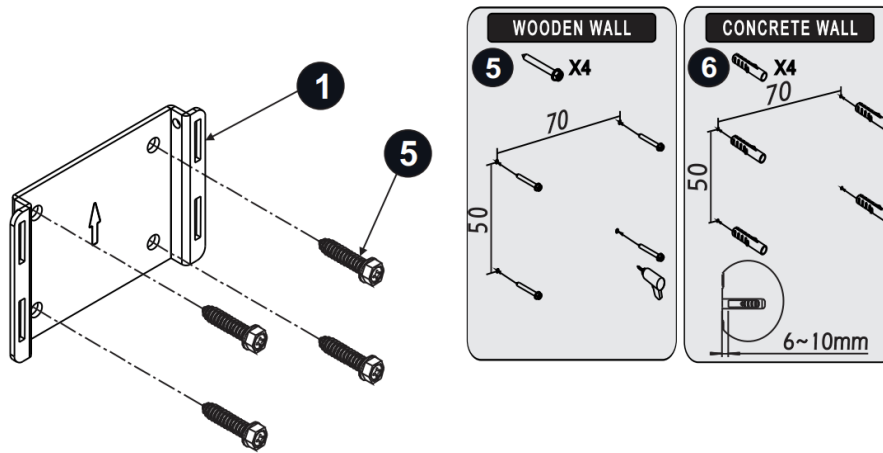

- To mount the panel PC on the wall, align the wall mount bracket attached to the panel PC with the wall mount plate on the wall and slide the panel PC downwards to hang the bracket on the mount plate. Secure the panel PC in place by tightening screws in the wall mount bracket.

将平板电脑安装在墙上时，将平板电脑附带的壁挂支架与墙上的壁挂板对齐，然后将平板电脑向下滑动，将支架挂在安装板上。通过拧紧壁挂支架中的螺钉将平板电脑固定到位

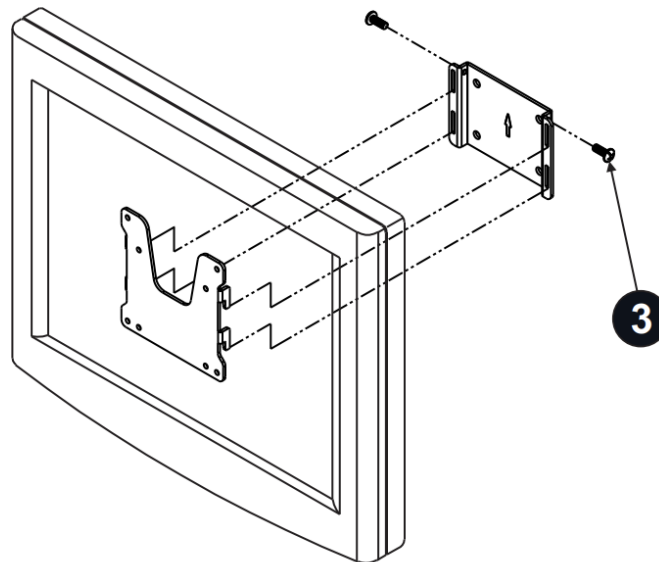

MAIN PARTS

ITEM	1	2	3
PARTS			
QTY	1	1	2

PARTS FOR TV BRACKETS

ITEM	4
PARTS	
QTY	4

PARTS FOR WALL BRACKETS

ITEM	5	6
PARTS		
QTY	4	4

2.6.2 Arm/ Stand Mounting 安装臂/支架

FPC-1736 can be mounted on a VESA-compliant arm mount with a 100mm interface pad. To affix the panel PC to an arm mount, follow the steps below.

FPC-1736 可以安装在带有 100 毫米接口垫的符合 VESA 标准的臂架上。要将平板计算机固定到臂架上，请按照以下步骤操作

1. Refer to the installation instruction of mounting arm/ stand to correctly assembly the arm/ stand onto the surface as a base.

参考安装臂/支架的安装说明，将臂/支架正确组装到表面上作为底座

2. Align the retention screw holes on the mounting arm interface with VESA holes in the panel PC and secure the panel PC with four M4 retention screws. Ensure that the thread depth of the screws on the rear panel does not exceed 4mm

将安装臂接口上的固定螺丝孔与平板计算器上的 VESA 孔对齐，并用四颗 M4 固定螺丝固定平板电脑。确保后面板螺丝的螺纹深度不超过 4mm

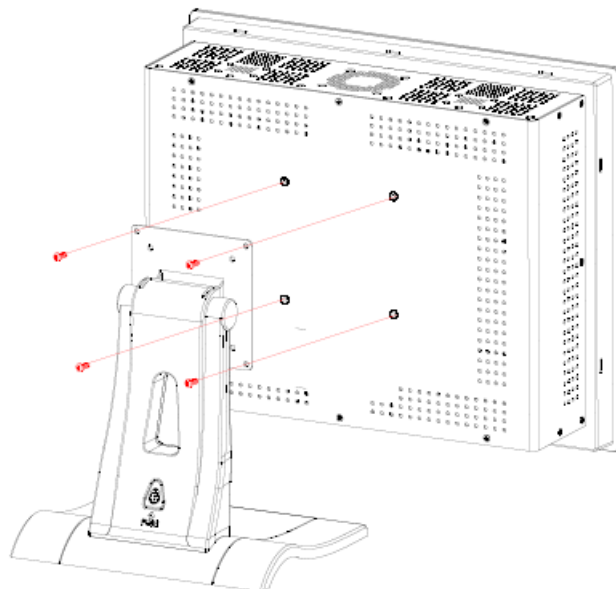

2.6.3 Panel Mounting 面板安装

To mount the flat bezel panel PC into a panel, follow the steps below.

要将平板计算器安装到面板中，请按照以下步骤操作

1. Prepare a panel cutout according to the panel PC dimensions. For FPC-1736 the panel cutout dimension is 382.5 x 315.2 mm

根据平板计算器尺寸准备面板开孔。FPC-1736 的面板开孔尺寸为 382.5 x 315.2 mm

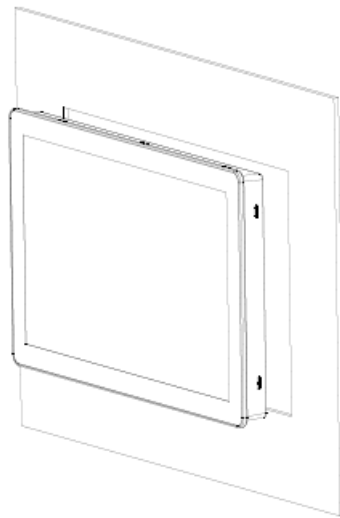

2. Install the panel PC in the cabinet and retrieve hook brackets from the accessory box

将平板计算器安装到机柜中，从附件盒中取出挂钩支架

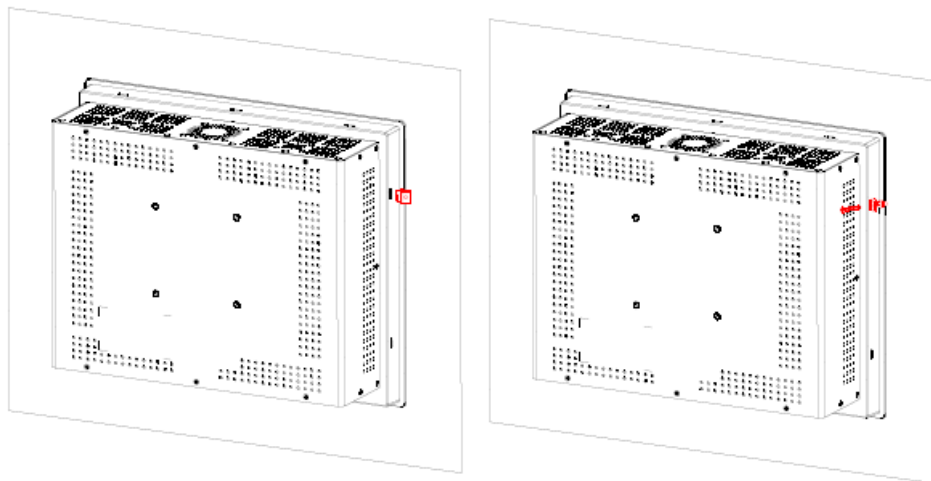

3. Insert the hook brackets into the holes following the direction of the arrows shown in below figure and hang the panel PC

将挂钩支架按照下图箭头方向插入孔中，将平板计算器挂起来

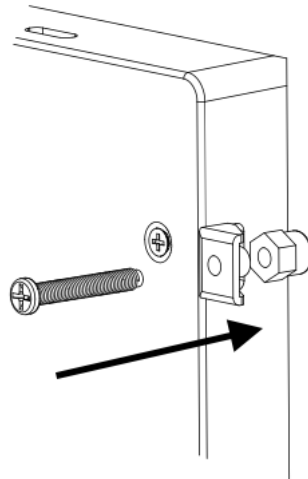

4. Tighten the screws to affix the panel PC in place, fasten all the hook bracket to ensure panel PC well fix at cabinet

拧紧固定平板计算器的螺丝，锁紧所有挂钩支架，确保平板电脑稳固地固定在机柜上

